



Engine	Xinchai 4D35G-007
Gross Power	48 kW (64 hp / 65 ps) @ 2,300 rpm
Net Power	45.6 kW (61 hp / 62 ps) @ 2,300 rpm
Breakout Force	20.4 kN
Rated Operating Capacity	720 kg
Bucket Capacity	0.4 m ³
Operating Weight	2,950 kg

365B

SKID STEER LOADER

365B SPECIFICATIONS >>>

ENGINE

Emission Regulation	Stage II
Make	Xinchai
Model	4D35G-007
Gross Power	48 kW (64 hp / 65 ps) @ 2,300 rpm
Net Power	45.6 kW (61 hp /62 ps) @ 2,300 rpm
Peak Torque	230 N · m @ 1,800 rpm
Number of Cylinders	4
Displacement	3.168 L
Cooling Type	Water

ELECTRICAL SYSTEM

System Voltage	12 V
Alternator Output	80 amps

CHAIN TANK

Drive Chain Size	80 HS
------------------	-------

TIRES

Ply Type	Vacuum tyre
Tire Size	10-16.5
Ply Rating	12

HYDRAULIC SYSTEM

System Type	Open
Standard Flow	75.9 L/min
Traveling Hydrostatic Pressure	32.5 MPa
Working Hydrostatic Pressure	21 MPa
Hydraulic Cycle Time, total	7.8 s
Raise	3.8 s
Dump	2.1 s
Lower (float down)	1.9 s

OPERATING WEIGHT

Operating Weight	2,950 kg
------------------	----------

PERFORMANCE

Static Tipping Load	1,440 kg
Rated Operating Capacity	720 kg
Boom Breakout Force	18.5 kN
Bucket Breakout Force	20.4 kN
Dump Clearance at Full Height Discharge	2,220 mm
Dump Reach at Full Height Discharge	540 mm
Maximum Dump Angle at Full Height	40°
Maximum Hinge Pin Height	2,923 mm
Bucket Rollback at Ground Level	30°
Ground Clearance	204 mm
Angle of Departure	26°
Front Clearance Radius with Bucket	1,800 mm

SERVICE CAPACITIES

Fuel Tank	100 L
Engine Oil	9.4 L
Cooling System	18 L
Hydraulic Reservoir	52 L
Hydraulic System Total	70 L
Chain Tanks, Each	8 L

OPTIONAL ATTACHMENTS

4 in 1 Bucket – 0.4 m ³	Auger
Rock Bucket – 0.4 m ³	Snow Blade
Scrap Bucket – 350 to 650 mm	Pick - up Sweeper
Hydraulic Hammer	Hydraulic Shear
Fork	Lift Boom

STANDARD EQUIPMENT

General Bucket –0.4 m ³
Control Safety Interlock
Boom Interlock
Quick Coupler
Open ROPS/FOPS Cab
Flow Standard-75.9 L/min

OPTIONAL EQUIPMENT

Enclosed ROPS/FOPS Cab with AC
Solid Tire
Tire Chains
Heater
A/C

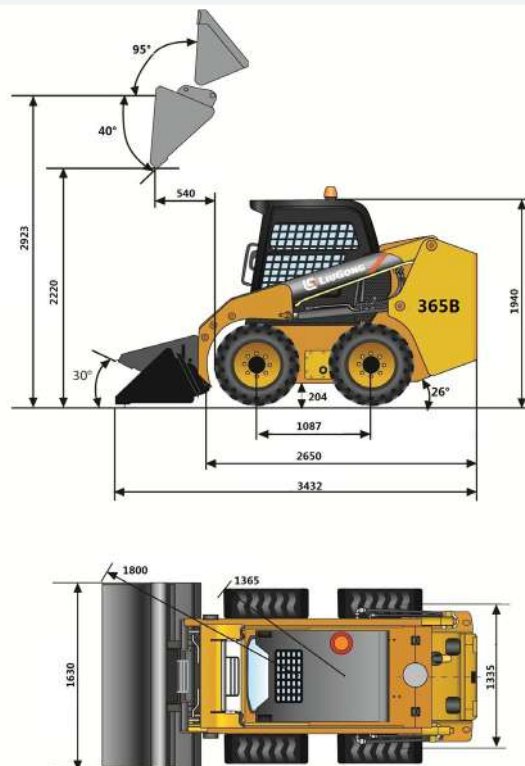

Guangxi Liugong Machinery Co., Ltd.

No. 1 Liutai Road, Liuzhou, Guangxi 545007, KHP

Представителство Liugong в Армения т.: +(374) 98 90 90 97 | +(374) 10 43 44 77 | email: specmashllc@mail.ru | specmash.am

03/2020 Designed by LiuGong
Replace the previous versions of 06/2019

Specifications and designs are subject to change without notice. Machines shown may include optional equipment. LiuGong standard and optional equipment may vary from region to region. Please consult your LiuGong dealer for information specific to your area. Engine power kW is converted to horsepower (1 kW=1.3596 ps and 1 kW=1.3410 hp) in this file.